

ZG-dSVG



V1.2





# 1

## 1.1

¥
¥

¥
¥

¥
¥
¥
¥
¥

¥
¥

¥  
¥  
¥  
¥

¥  
¥  
¥  
¥  
¥

¥  
¥  
¥  
¥  
¥

¥  
¥  
¥

¥

¥  
¥  
¥

¥

¥

## 2

### 2.1

3)

,

2.1

### 2.2

## 2.3

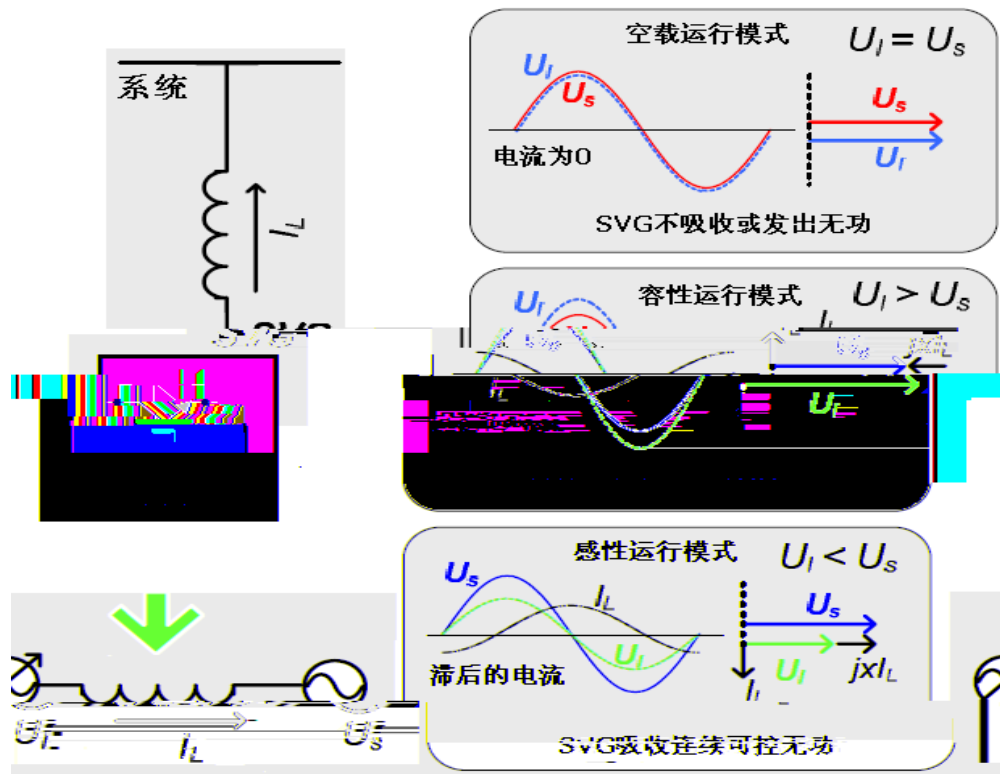

$$I_1 = (U_s - U_1) \div jX_L$$



## 2.4

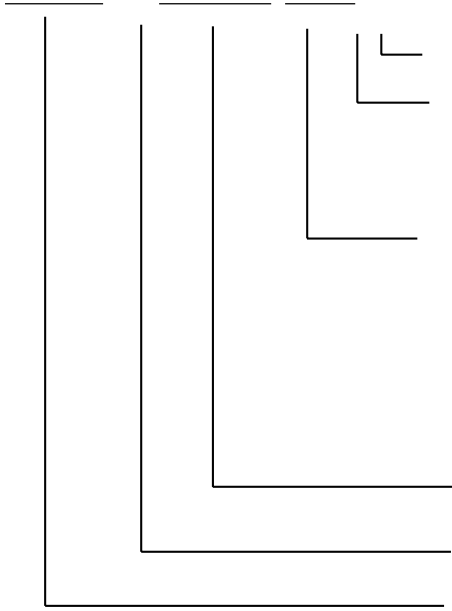

# 3

## 3.1

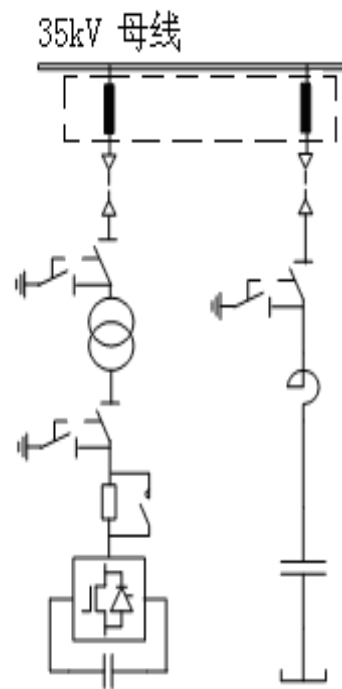
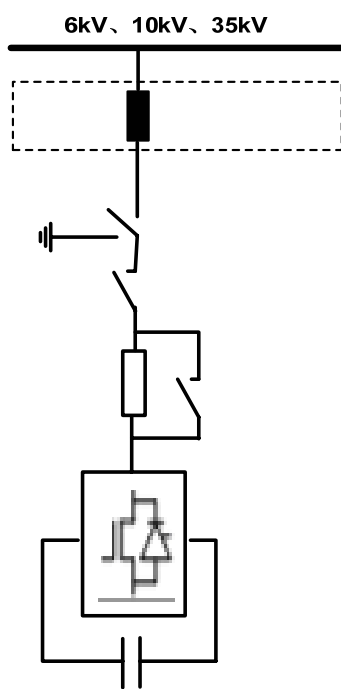

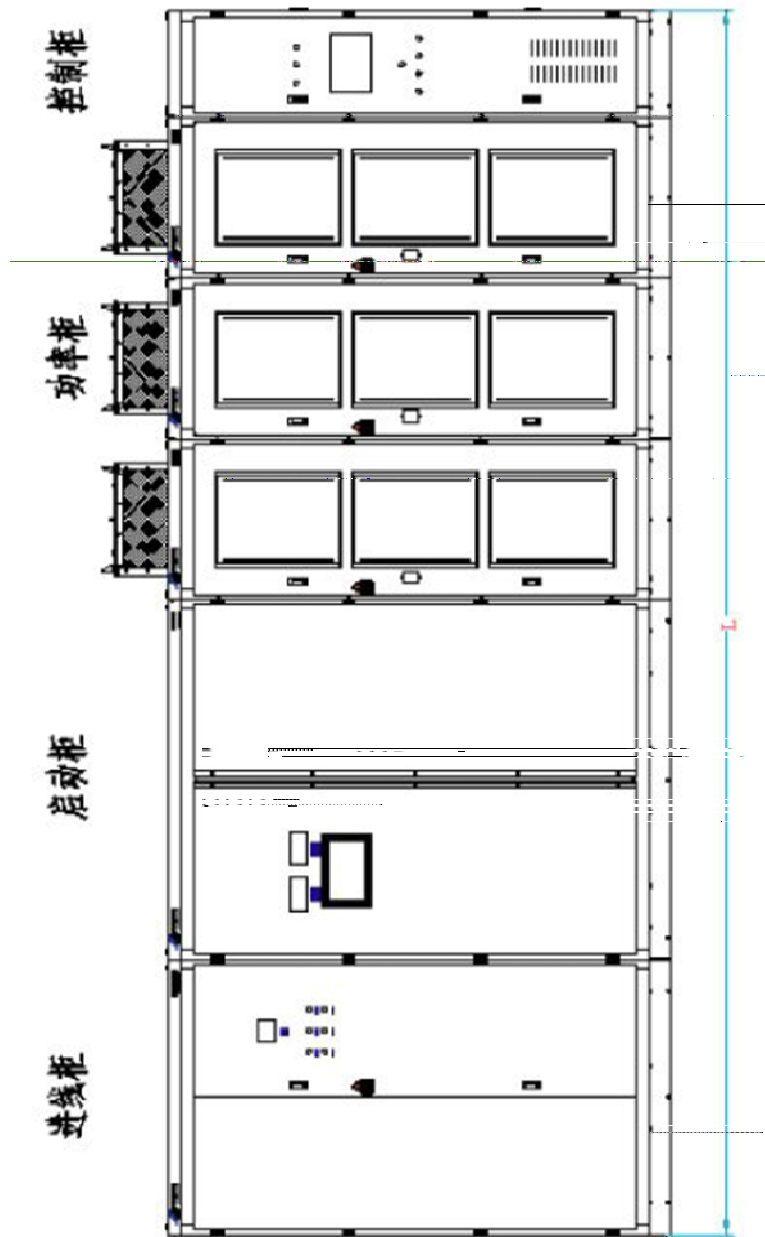
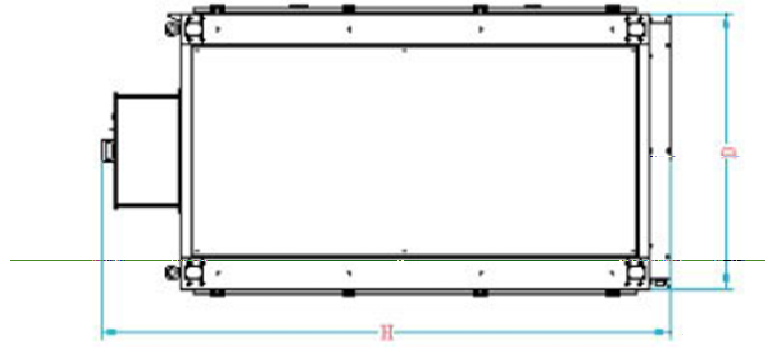

3-3 6kV 10kV ZG-dSVG

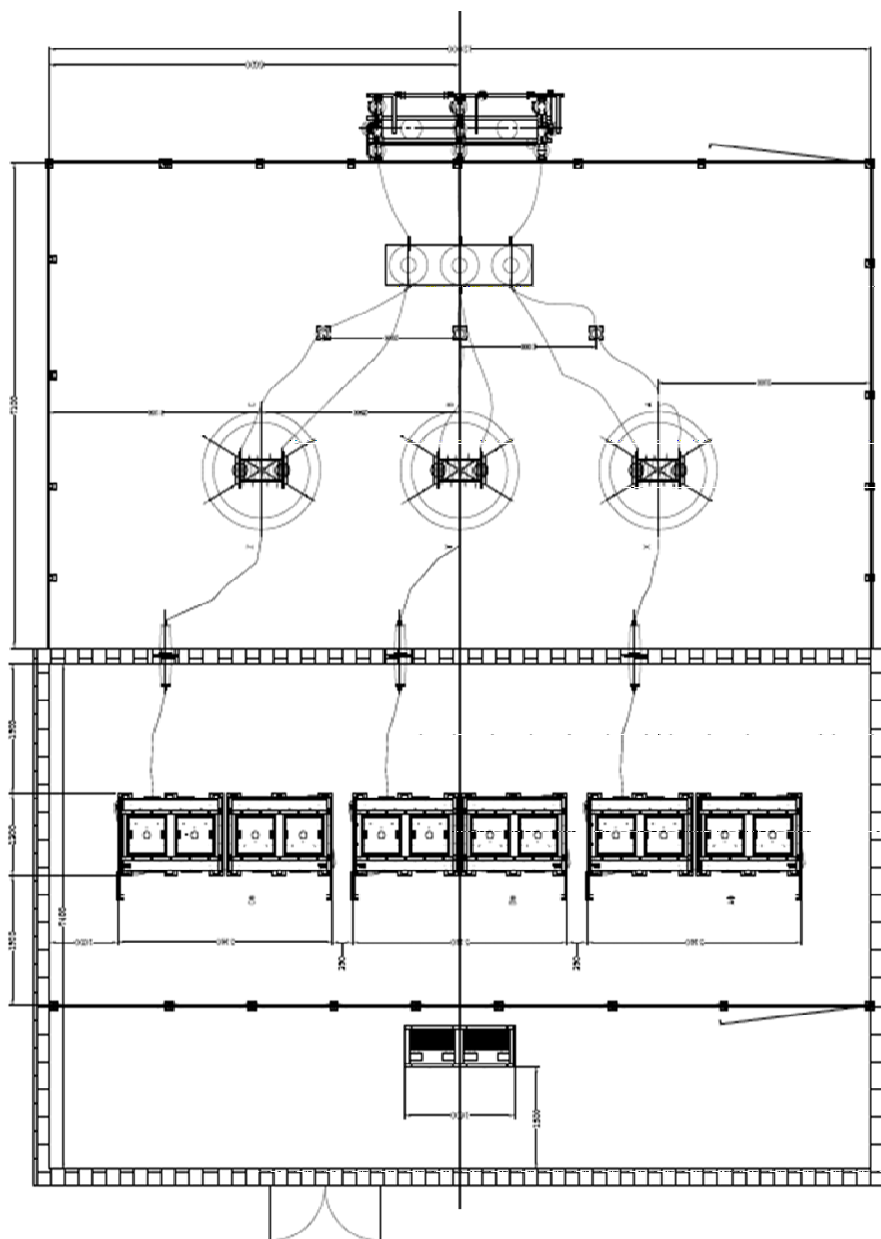

3-4 35kV

ZG-dSVG

### 3.2

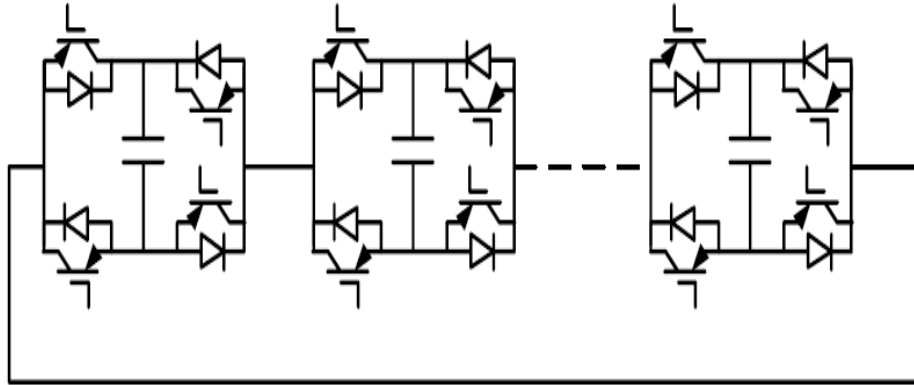

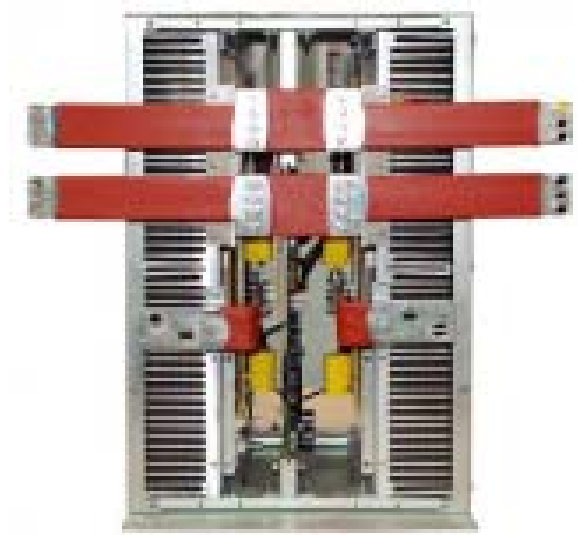

3-6

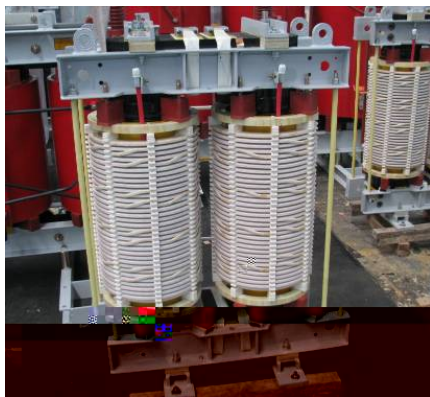

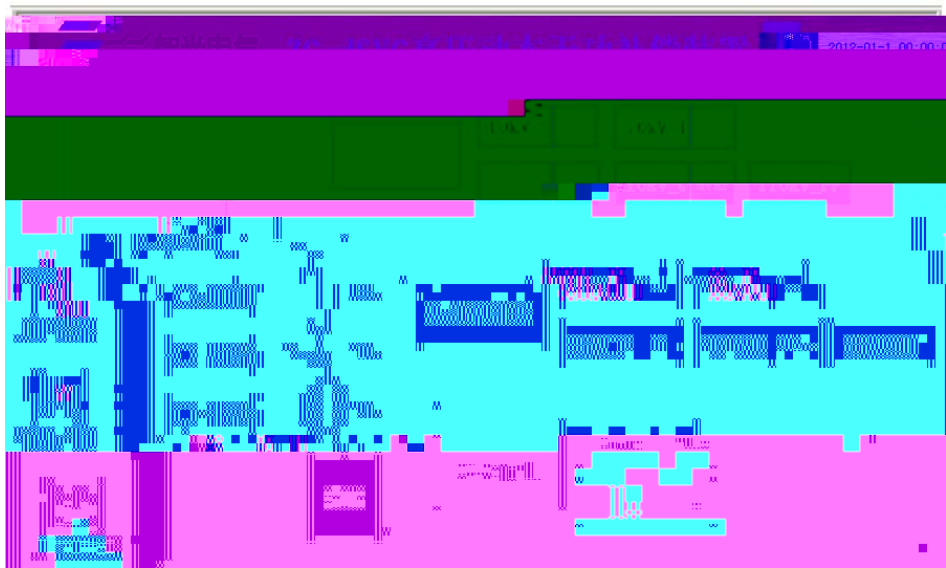

3-9

4

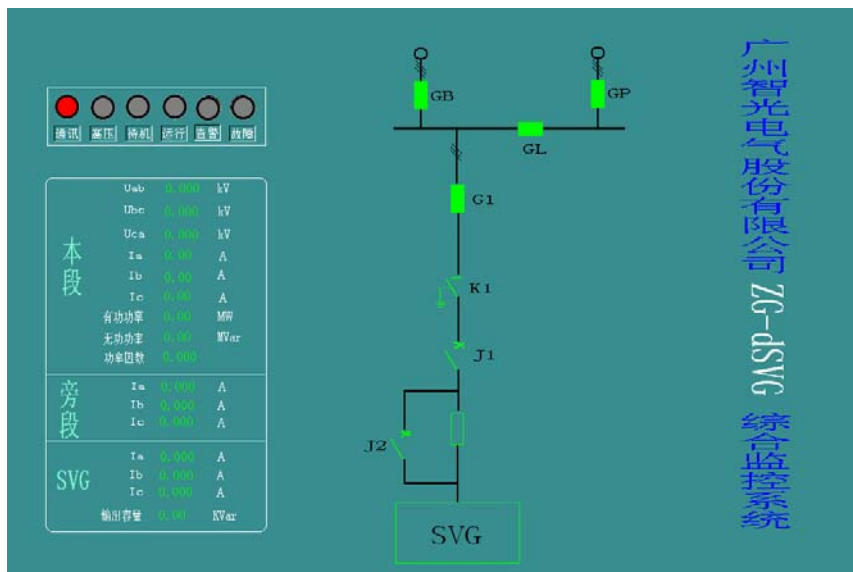

3-10

3

1-25

4

6



5

6

7

8

9

10

11

**4**

**4.1**

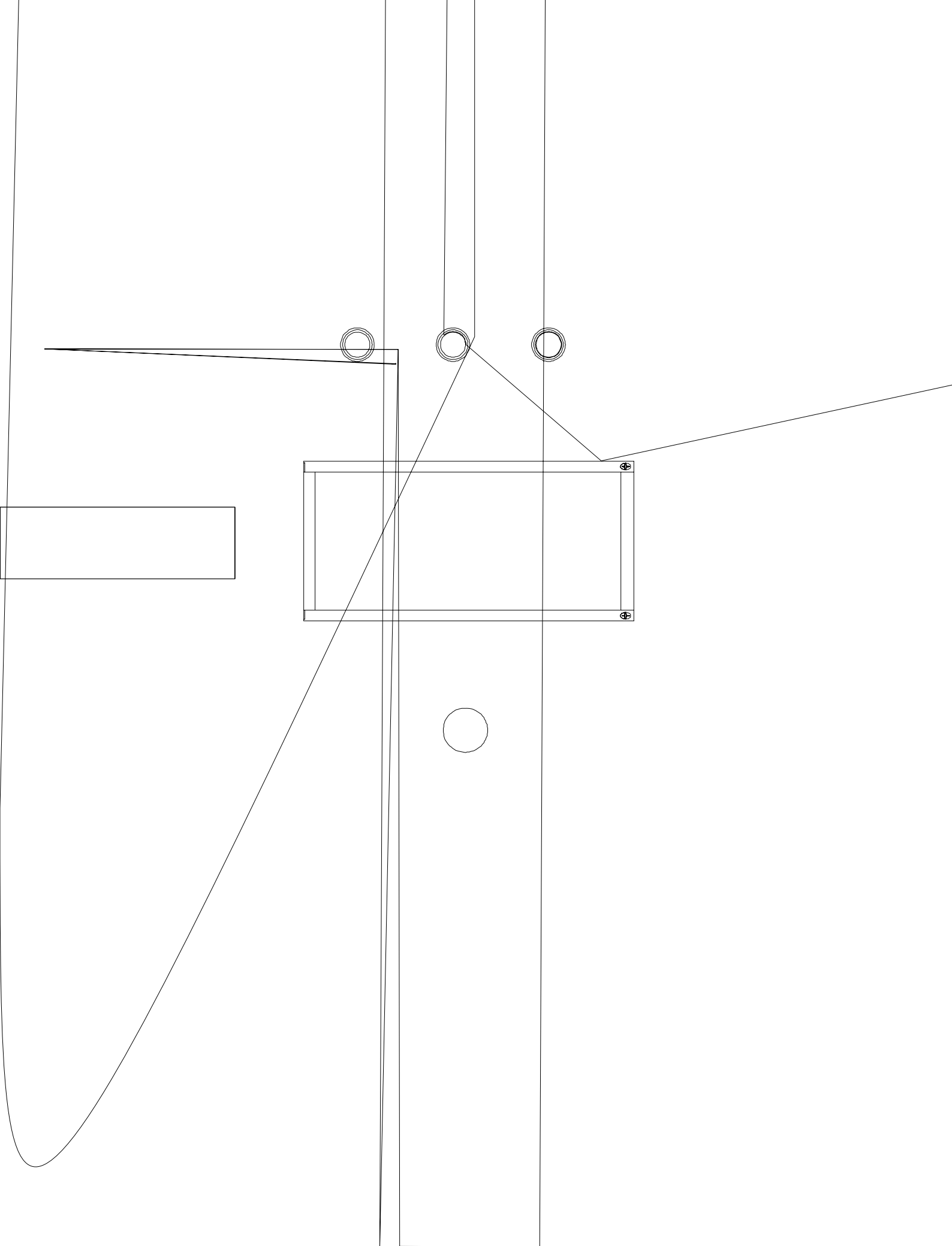

	/	

4-1

ZG-dSVG

### 4.3

TPC7063H

TPC7062K

4

# 5

## 5.1

1. 380V
2. /
- 3.
- 4.
- 5.
- 6.

## 5.2

1. 380V
- 2.
- 3.
- 4.
- 5.

## 5.3

- 1.

2.

380V

3.

4.

5.

6.

7.

## 5.4

1.

2.

3.

4.

3-6

5.

6.

7.

# 6

## 6.1



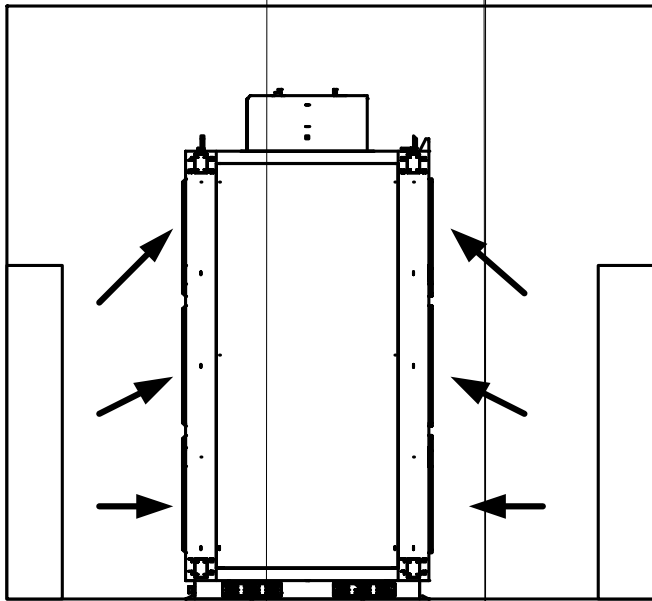

6.2

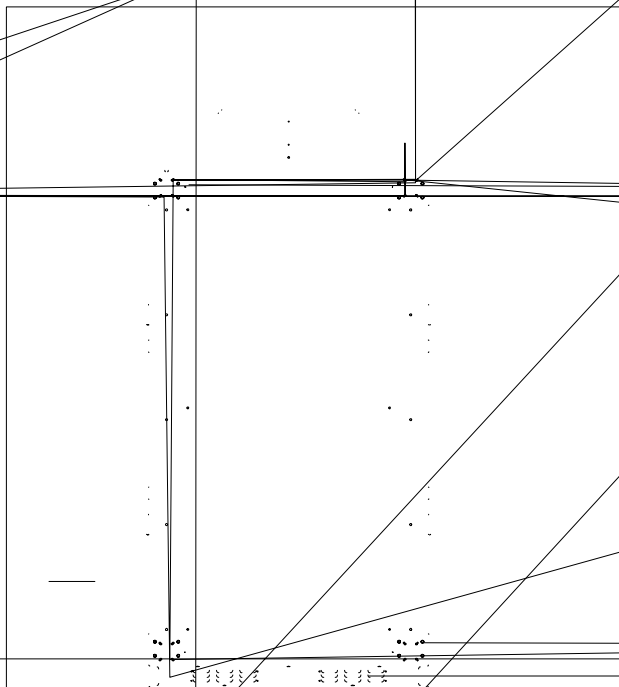

### 6.3

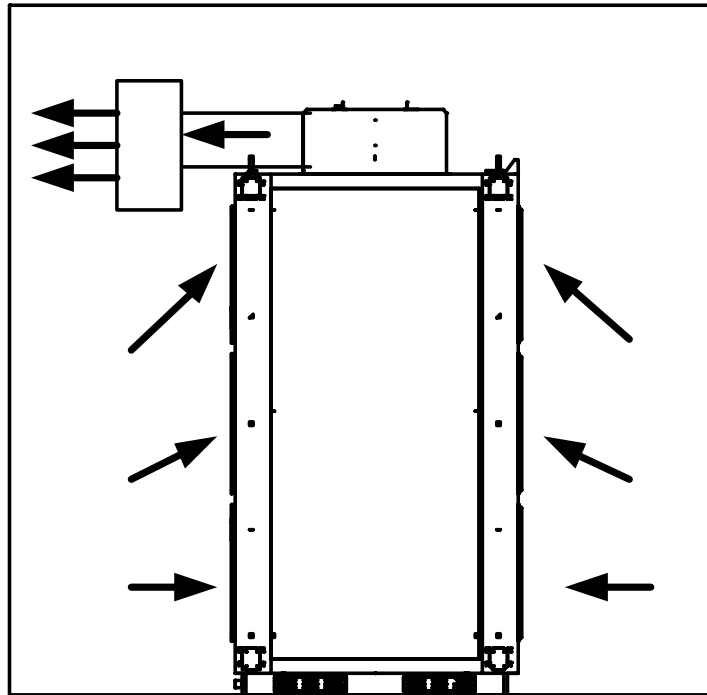

## 6.4

# 7

7-1 ZG-dSVG

1		1.IGBT 2. 3. 4. 5.	1. 2. 3. 4.
2		1. 2. 3. 4.	1. 2. 3. 4.
3		1. PT 2. 3. 4. 5. 6. 7.	1. SVG PT 2. 3. 4. 5. 6.
4		1. 2. 3. 4. 5.	1. 2. 3. 4. 5.
5	/	1. 2. 3. 4. 5.	1. 2. 3. 4.
6		1.PT	1.

		2. 3.	2.
7	1/2	1. 2. 3. 4.	1. 2. 3.
8		1. 2. 3. 4.	1. 2. 3.
9		1. 2. 3. 4.	1. 2. 3.
10		1. 2. 3.	1. 2.
11		1. 2.	1. 2.
12		1. 2. 3. 4.	1. 2. 3.
13		1. UPS 2. 3. 4.	1. UPS 2. 3. 4.
14			1. 2.
15		1. 2. 3. PT 4.	1. 2. 3. PT SVG 4. PT
16	/ /	1. 2. 3.	1. 2. 3.
17		1. 2. 15V 3. 4.	1. 2. 15V 3. 4.

ZG-dSVG

# 8

## 8.1

## 8.2

1

2

3

4

5

**8.5**